

## FUNCTION

Our thermostatic mixing valves art. S100 - S101 - S102 are used in hot water solar systems. They provide stable mixed water temperature to the users. This allows to maintain the desired water temperature according to the established value despite the pressure or temperature variations of incoming hot and cold water or used water quantity. Our thermostatic mixing valves have also an automatic anti-burn security, which stops hot water flow in case of lack of incoming cold water.

Thermostatic mixing valves includes N.2 non-return valves integrated inside the male connections to avoid back fluid in the system



*Art. S100*

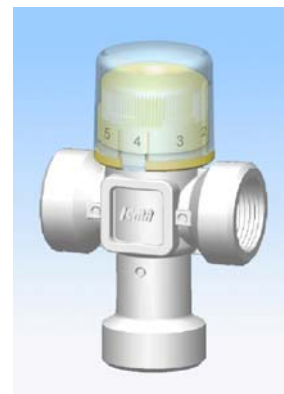

*Art. S101*

*Art. S102 with non-return valves*

## PRODUCTS

Art.	Size	Connections
93S100AD05	G ½" M	male unions
93S100AE05	G ¾" M	male unions
93S100AF05	G 1" M	male unions
93S101AD05	G ½" F	female
93S101AE05	G ¾" F	female
93S101AF05	G 1" F	female
93S102AE05	G ¾" M	male unions with non-return valves

## TECHNICAL FEATURES

Body	Brass CW 617 N - UNI EN 12165
Obturator	Brass CW614N -UNI EN 12164
Spring	Stainless Steel INOX
Headwork	Grivory
Headwork fixing	Grivory
Cover	ABS transparent
O-Ring	EPDM PEROX - (high resistance )
Fluid:	water
Max glycolated solutions:	50%
Temperature range:	30-60°C
Factory set:	38±2°C
Max operating pressure (static):	10 bar
Max operative pressure (dynamic):	5 bar
Max inlet temperature:	100°C
Max inlet pressure ratio:	2:1

### NON-RETURN VALVES

Body	Brass CW 614 N - UNI EN 12164
O-Ring	EPDM PEROX - (high resistance)
Spring	Stainless Steel INOX

## DIMENSIONS

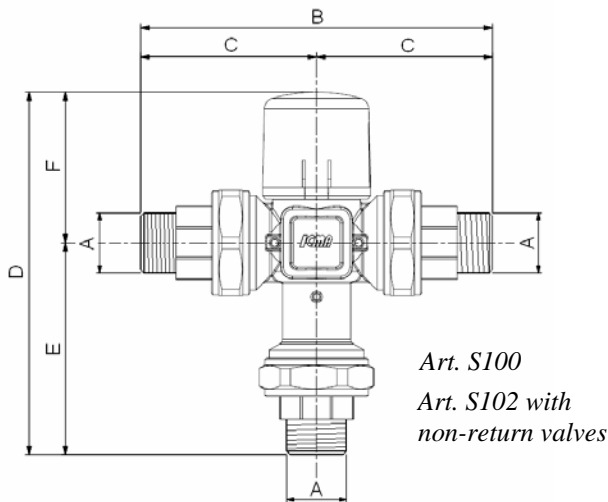

CODE	A	B	C	D	E	F
93S100AD05	1/2"	124	62	132	80	53
93S100AE05	3/4"	124	62	132	80	53
93S100AF05	1"	140	70	152	87	65
93S102AE05	3/4"	124	62	132	80	53

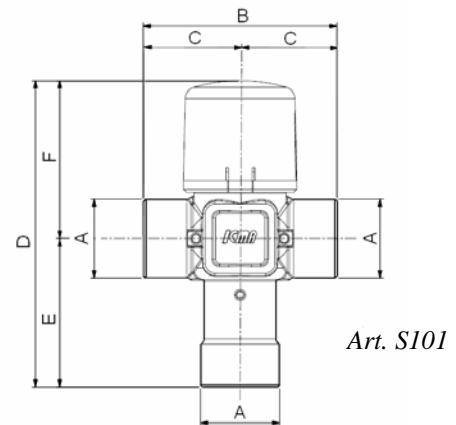

CODE	A	B	C	D	E	F
93S101AD05	1/2"	65	32.5	103	50	53
93S101AE05	3/4"	68	34	106	53	53
93S101AF05	1"	84	42	123	61	62

## OPERATING PRINCIPLE

The diverting valve is located at the entrance of the kit receiving hot water coming from solar panels. According to the temperature calibration the valve automatically diverts the water between the domestic system and the hot-water heater.

The valve provides the water flow by exploiting solar energy and reducing as much as possible the use of the hot-water heater.

At the exit of the kit there is an anti-burn thermostatic mixing valve which sends the water to the users controlling and restricting the temperature.

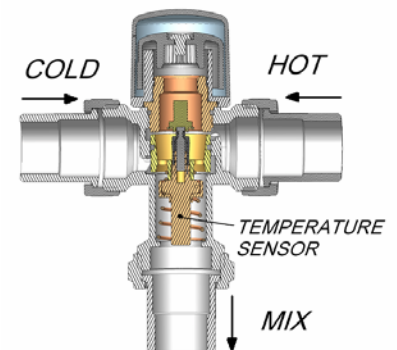

## NON-RETURN VALVES

Thermostatic mixing valves Art.S102 includes N.2 non-return valves integrated inside the male connections to avoid back fluid in the system.

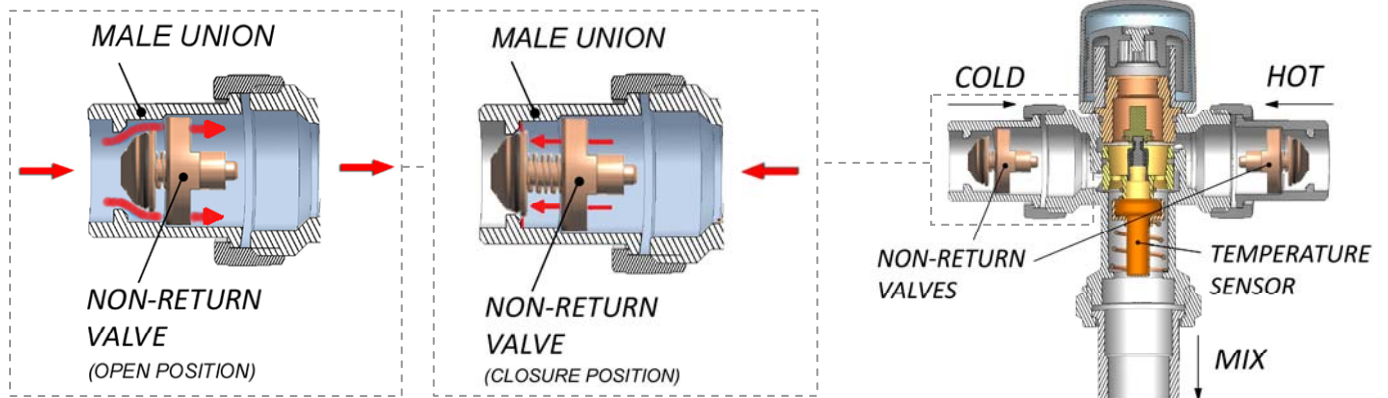

## INSTALLATION

Before using the mixing valve, make sure all pipes are clean to prevent equipment malfunctions; we also recommend installing water filters.

On the mixing valve body you can find:

- hot water inlet marked in red
- cold water inlet marked in blue
- mixed water exit

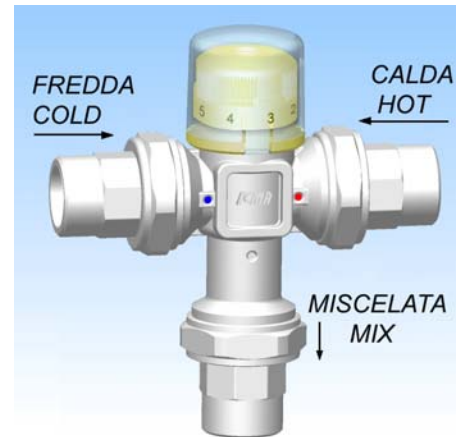

## TEMPERATURE REGULATION

The temperature is adjusted using the mixing valve regulating knob.

*Reference conditions:*

*T<sub>hot</sub>: 68°C*

*T<sub>cold</sub>: 13°C*

*Inlet pressure:*

*3+3 balanced*

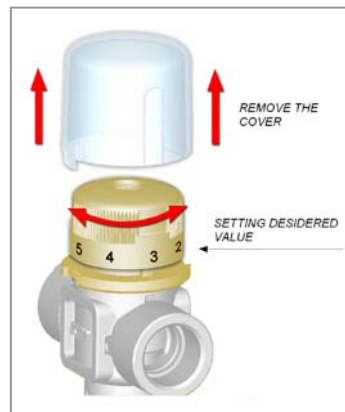

## TEMPERATURE RANGE

Position	1	2	3	4	5	6
°C	30	35	40	45	50	60

## DIAGRAM

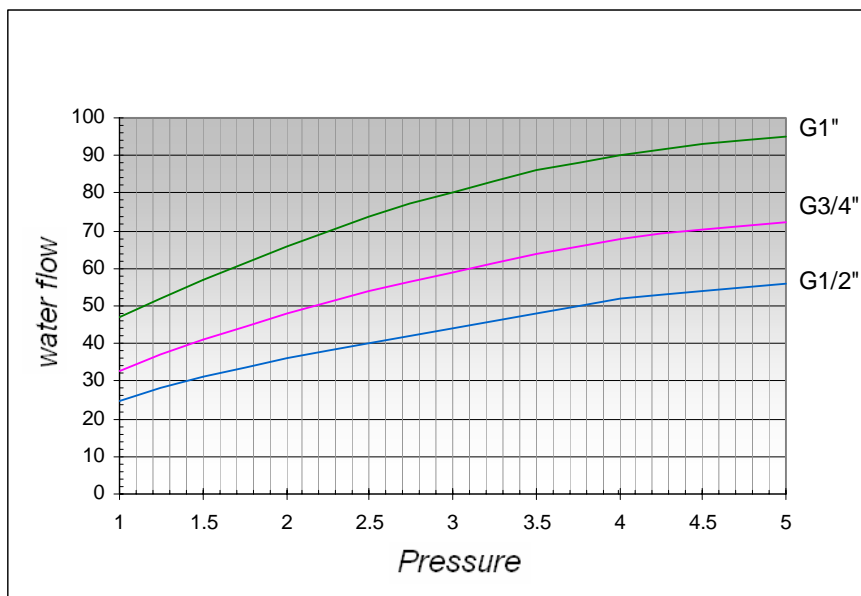

Kv / m <sup>3</sup> h	
G 1/2"	1.5
G 3/4"	2
G 1"	3

## APPLICATION DIAGRAM

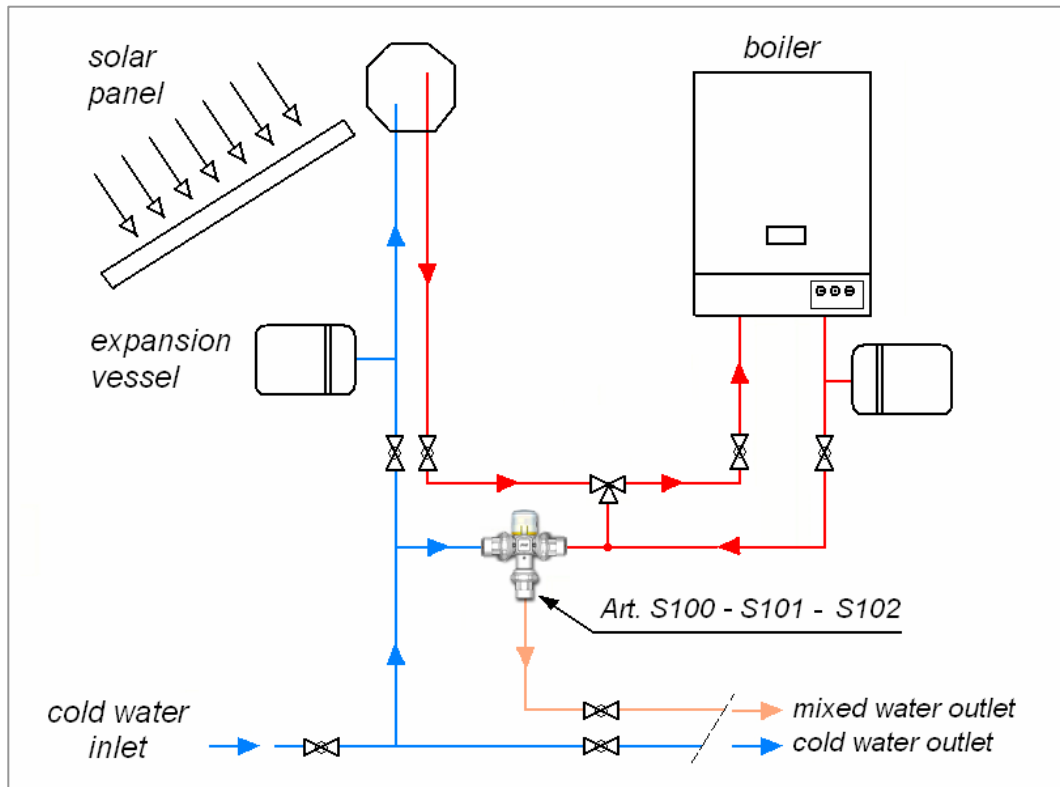

### SAFETY

Read the assembly and start-up instructions and comply with them scrupulously before starting the system to prevent accidents and damage to the system caused by improper use. Remember that the guarantee will be forfeited in the event of any unauthorised changes or tampering with the device during assembly and construction. Comply with all safety warnings, and if you have any doubts about use or changes to parameters or functions, request the assistance of qualified service personnel.

Assembly and inspection operations must absolutely be performed by qualified, authorised personnel aware of the instructions contained herein. Make sure that the equipment is turned off before beginning any work on it.